

KALDEWEI

CONODUO 734

Body & Soul



Technical whirl datasheet

CONODUO 734

Body & Soul

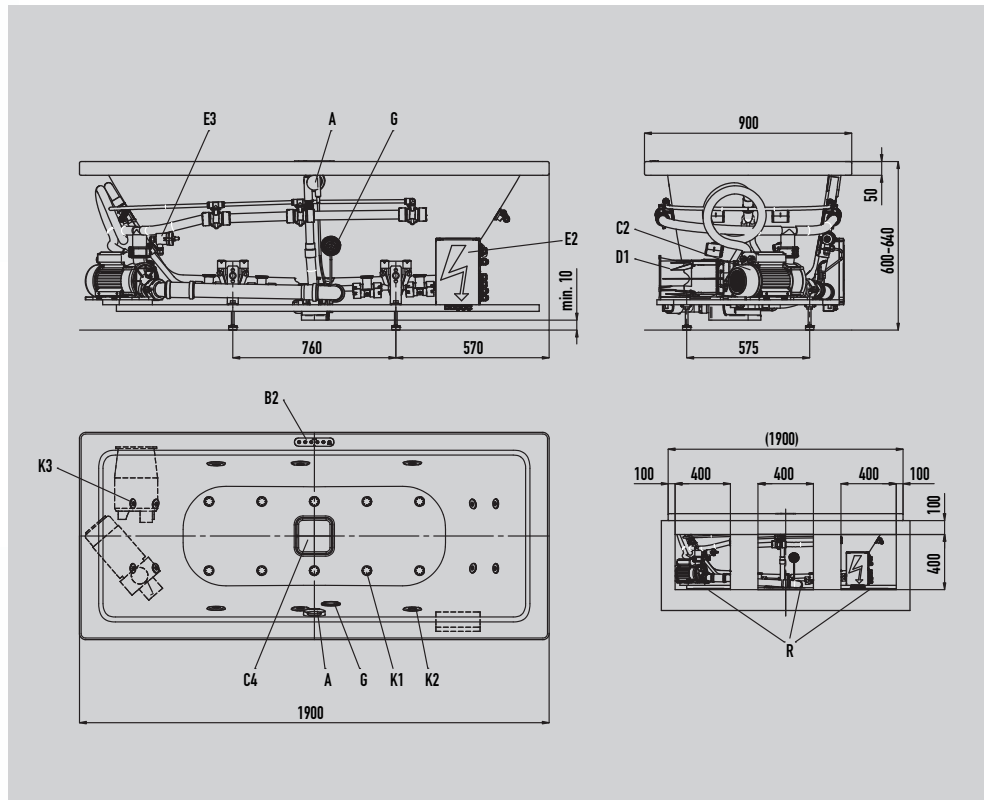

Similar illustration. In the configuration with whirl systems, all visible parts are white.

Attributes

A	Drain and overflow fitting
B2	Keypad
C2	Pump side area
C4	Bottom suction
D1	Blower bottom area
E2	Cable junction box
E3	Level sensor
G	Illumination - spotlight / spectral light
K1	Floor jets
K2	Side jets
K3	Micro jets
R	Inspection hole